



Description

The AD6C211-L is a bi-directional, single-pole, single-throw, normally open solid-state relay. It provides a load current of 150mA, a high blocking voltage of 400V, and current limiting circuitry in a compact 6 pin DIP package. Current limiting circuitry provides a level of protection against increased load currents or transient current spikes by active current reduction across the device, thereby protecting itself and downstream components.

The AD6C211-L comes standard in a miniature 6 pin DIP package making it ideal for high-density board applications.

Applications

- Reed Relay Replacement
- Multiplexers
- Meter Reading Systems
- Medical Equipment
- Battery Monitoring

Schematic Diagram

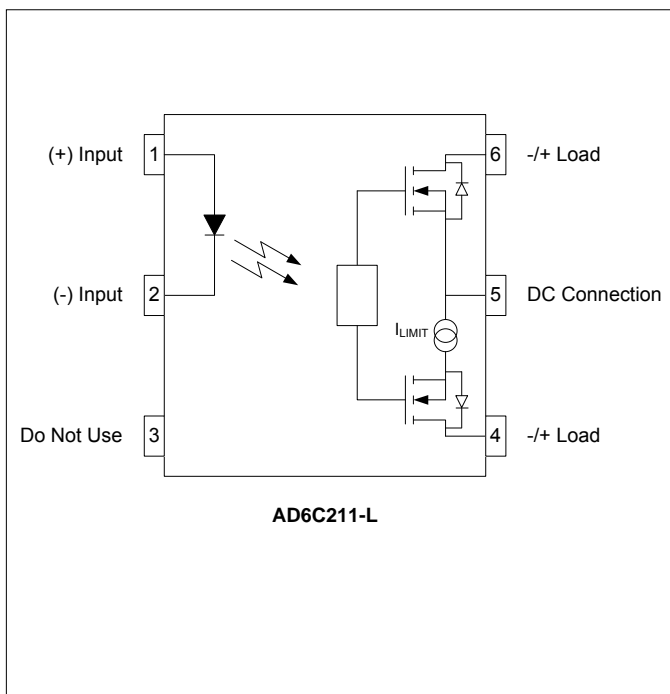

Features

- High Isolation Voltage (3750V_{RMS})
- Low Input Control Current (3mA TYP)
- 150mA Maximum Continuous Load Current
- 25 Ω Maximum On-Resistance
- Active Current Limiting Protection
- Long Life / High Reliability
- RoHS / Pb-Free / REACH Compliant

Agency Approvals

UL / C-UL: File # E201932
 VDE: File # 40035191 (EN 60747-5-2)

Absolute Maximum Ratings

The values indicated are absolute stress ratings. Functional operation of the device is not implied at these or any conditions in excess of those defined in electrical characteristics section of this document. Exposure to absolute Maximum Ratings may cause permanent damage to the device and may adversely affect reliability.

Storage Temperature	-55 to +125°C
Operating Temperature	-40 to +85°C
Continuous Input Current	50mA
Transient Input Current	500mA
Reverse Input Control Voltage	6V
Input Power Dissipation	40mW
Output Power Dissipation	800mW
Solder Temperature – Wave (10sec)	260°C
Solder Temperature – IR Reflow (10sec)	260°C

Ordering Information

Part Number	Description
AD6C211-L	6 pin DIP, (50/Tube)
AD6C211-LS	6 pin SMD, (50/Tube)
AD6C211-LSTR	6 pin SMD, Tape and Reel (1000/Reel)

NOTE: Suffixes listed above are not included in marking on device for part number identification

Electrical Characteristics, $T_A = 25^\circ\text{C}$ (unless otherwise specified)

Parameter	Symbol	Min.	Typ.	Max.	Units	Test Conditions
Input Specifications						
LED Forward Voltage	V_F	-	1.2	1.5	V	$I_F = 10\text{mA}$
LED Reverse Voltage	BV_R	6	-	-	V	$I_R = 10\mu\text{A}$
Turn-On Current	I_F	-	3	5	mA	$I_O = 150\text{mA}$
Turn-Off Current	I_{FOFF}	-	0.5	-	mA	-
Output Specifications						
Blocking Voltage	V_B	400	-	-	V	$I_O = 1\mu\text{A}$
Continuous Load Current	I_O	-	-	150	mA	$I_F = 5\text{mA}$
Current Limit (AC or DC connection)	I_{LIMIT}	180	300	-	mA	$I_F = 5\text{mA}$
On Resistance	R_{ON}	-	18	25	Ω	$I_F = 5\text{mA}, I_O = 150\text{mA}$
Leakage Current	I_{leak}	-	0.2	1	μA	$I_F = 0\text{mA}, V_O = 400\text{V}$
Output Capacitance	C_{OUT}	-	25	50	pF	$I_F = 0\text{mA}, f = 1.0\text{MHz}$
Offset Voltage	V_{OFFSET}	-	-	0.2	mV	$I_F = 5\text{mA}$
Coupled Specifications						
Turn-On Time	T_{ON}	-	1.5	5.0	mS	$I_F = 5\text{mA}, I_O = 150\text{mA}$
Turn-Off Time	T_{OFF}	-	0.5	1.0	mS	$I_F = 0\text{mA}, I_O = 150\text{mA}$
Coupled Capacitance	C_{COUPLED}	-	3	-	pF	
Contact Transient Ratio	-	2,000	7,000	0	V/μS	$dV = 50\text{V}$
Isolation Specifications						
Isolation Voltage	V_{ISO}	3,750	-	-	V_{RMS}	$\text{RH} \leq 50\%, t = 1\text{min}$
Input-Output Resistance	$R_{\text{I-O}}$	-	10^{12}	-	Ω	$V_{\text{I-O}} = 500V_{\text{DC}}$

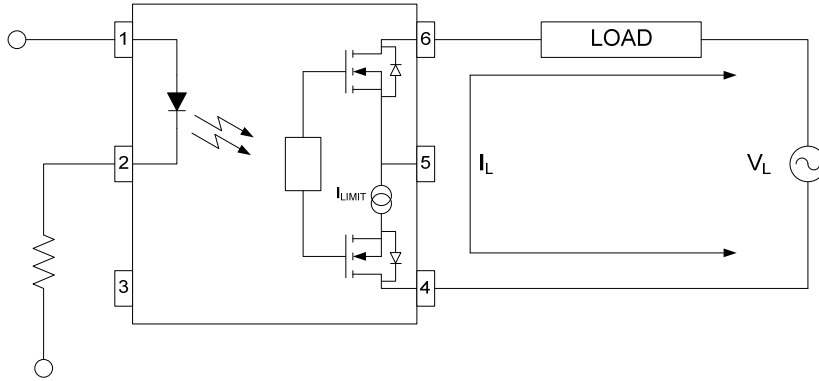
AD6C211-L Current Limiting Connection Diagrams, $T_A = 25^\circ\text{C}$ (unless otherwise specified)
Connection Diagrams
Comments
Option A: Normal AC Load Configuration

On Resistance: R_{TYP}
 Current Limit: I_{LIMIT}

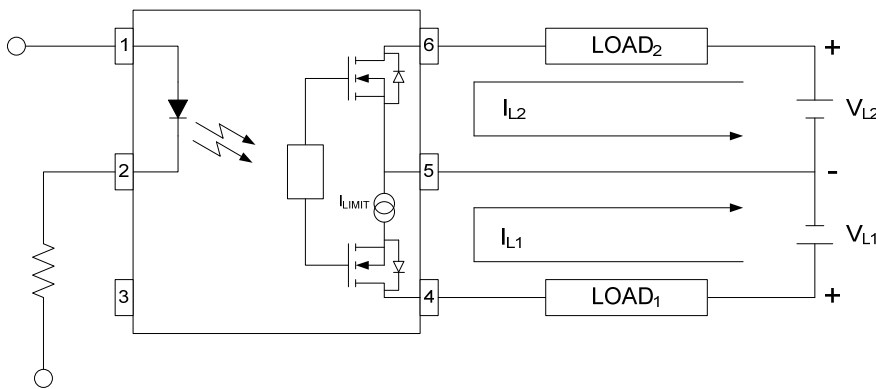
Option B: Separate Loads & Load Voltages

On Resistance:
 Load₁ $\sim (R_{TYP} / 2) + 3\Omega$
 Load₂ $R_{TYP} / 2$
 Current Limit:
 Load₁ I_{LIMIT}
 Load₂ N/A

- Sum power of loads not to exceed maximum package power dissipation

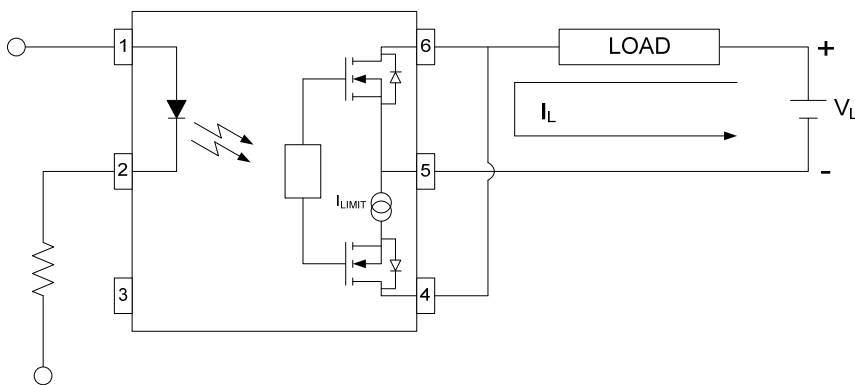
Option C: DC Load with Minimal Resistance and No Current Limit

On Resistance: $R_{TYP} / 4$
 Current Limit: None

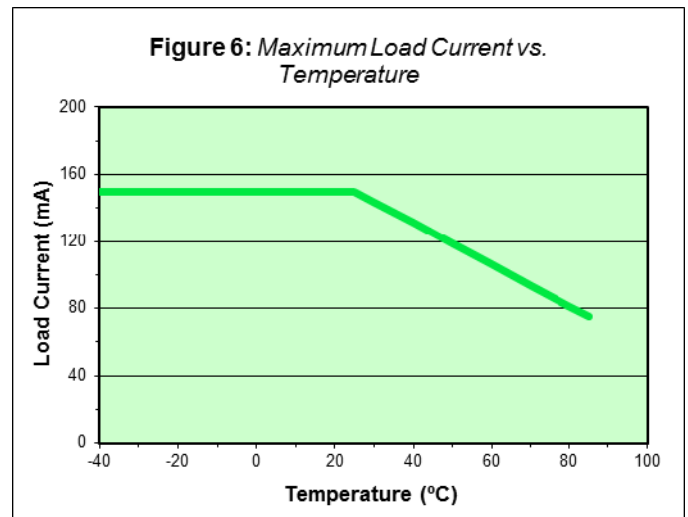
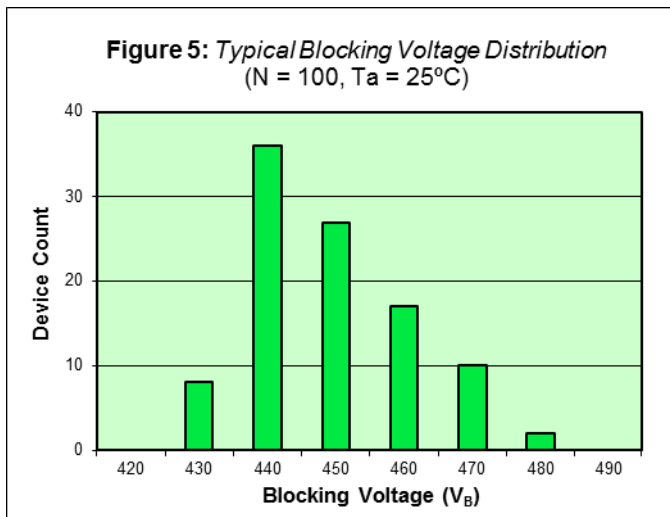
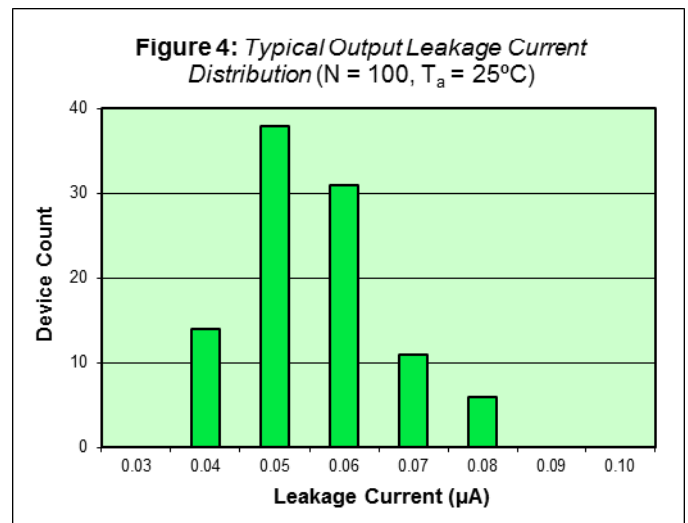
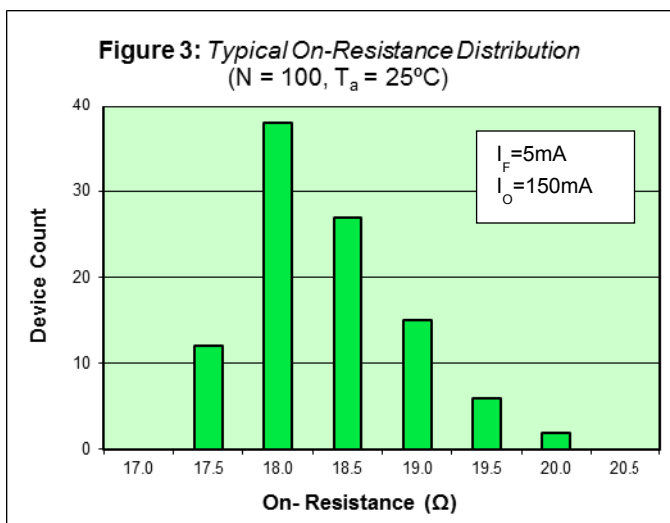
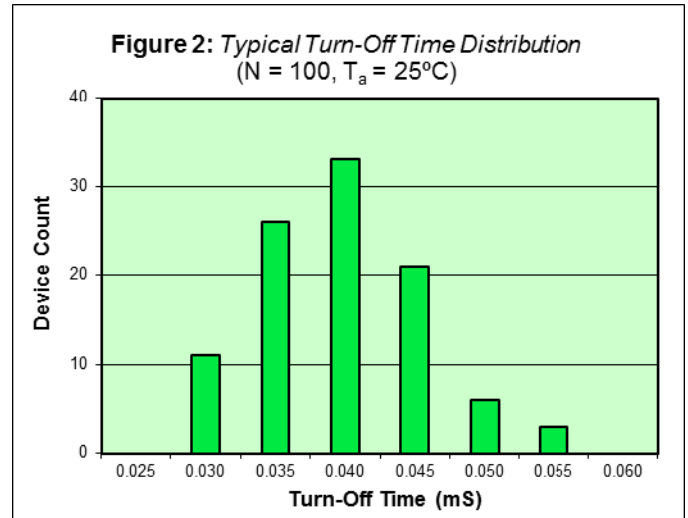
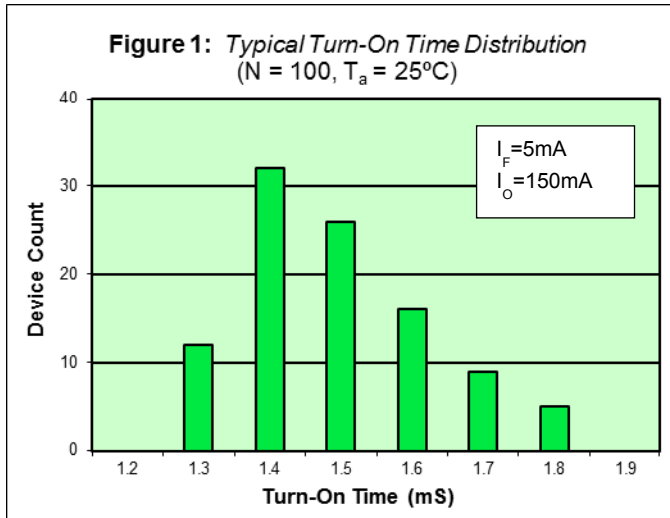
AD6C211-L Performance & Characteristics Plots, $T_a = 25^\circ\text{C}$ (unless otherwise specified)

AD6C211-L Solder Temperature Profile Recommendations
(1) Infrared Reflow:

Refer to the following figure as an example of an optimal temperature profile for single occurrence infrared reflow. Soldering process should not exceed temperature or time limits expressed herein. Surface temperature of device package should not exceed 250°C:

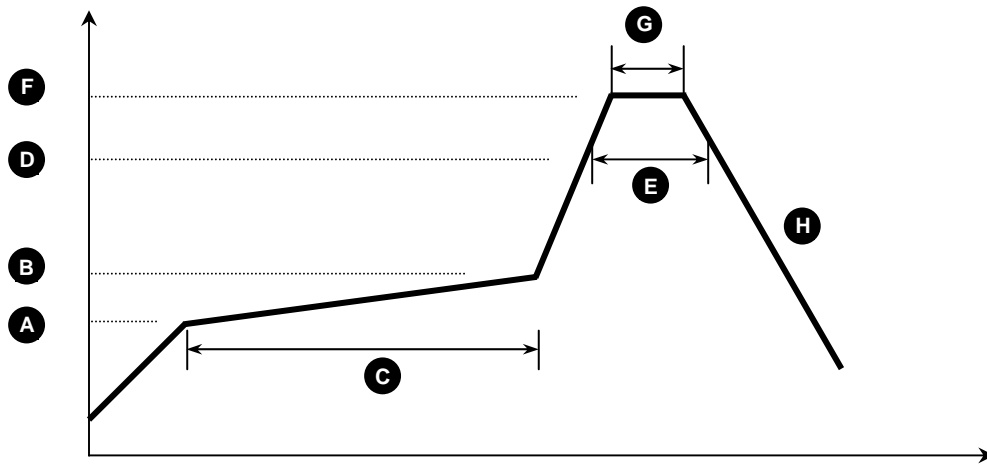

Figure 1

Process Step	Description	Parameter
A	Preheat Start Temperature (°C)	150°C
B	Preheat Finish Temperature (°C)	180°C
C	Preheat Time (s)	90 - 120s
D	Melting Temperature (°C)	230°C
E	Time above Melting Temperature (s)	30s
F	Peak Temperature, at Terminal (°C)	260°C
G	Dwell Time at Peak Temperature (s)	10s
H	Cool-down (°C/s)	<6°C/s

(2) Wave Solder:

Maximum Temperature: 260°C (at terminal)
 Maximum Time: 10s
 Pre-heating: 100 - 150°C (30 - 90s)
 Single Occurrence

(3) Hand Solder:

Maximum Temperature: 350°C (at tip of soldering iron)
 Maximum Time: 3s
 Single Occurrence

AD6C211-L Package Dimensions

6 PIN DIP Package

Note: All dimensions in inches ["] with millimeters in parenthesis ()
Device Weight: 0.45g

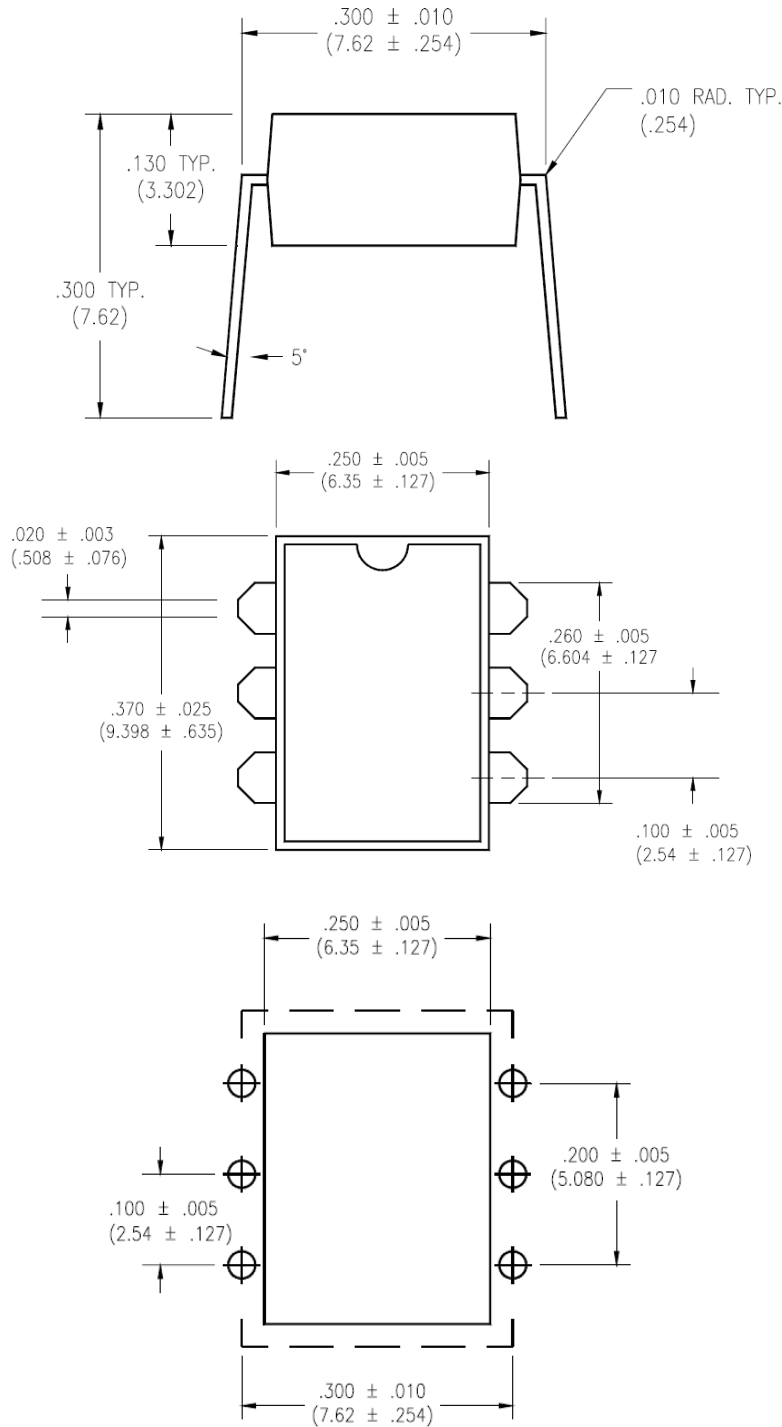

AD6C211-L Package Dimensions

6 PIN SMD Surface Mount Package (-S)

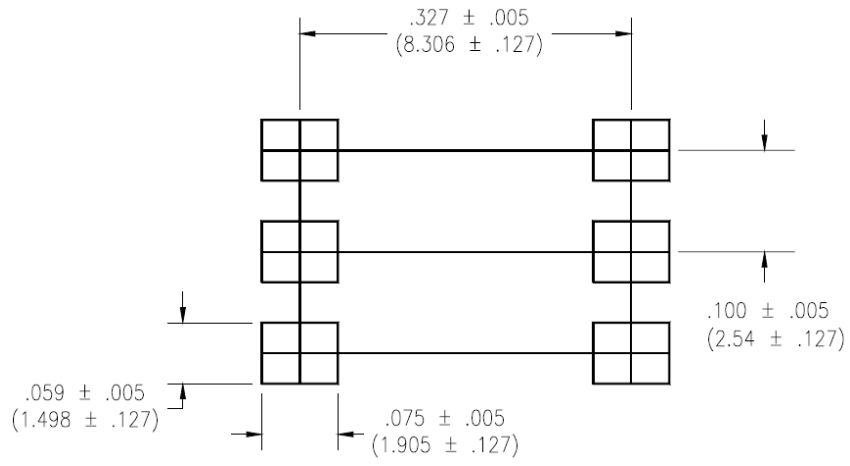
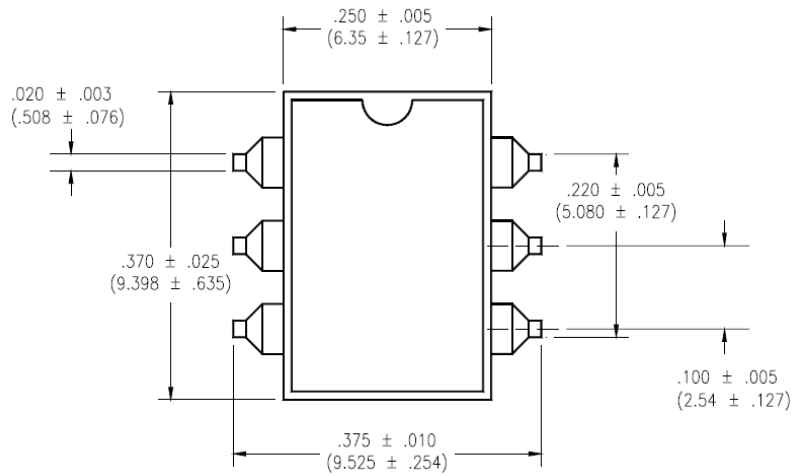
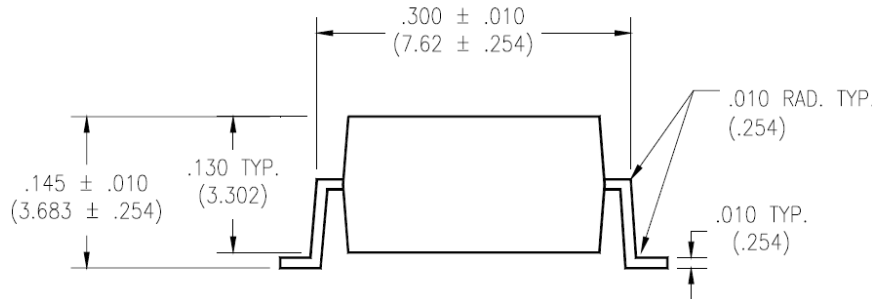
Note: All dimensions in inches ["] with millimeters in parenthesis ()
Device Weight: 0.45g

AD6C211-L Package Dimensions

6 PIN SMD Tape & Reel (-STR)

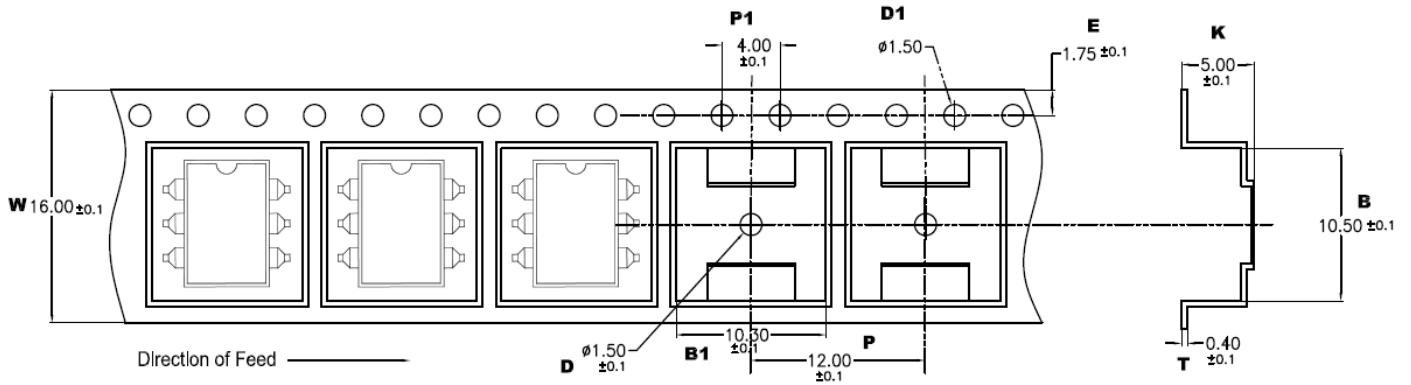
Note: All dimensions in millimeters

W	B	B1	P	P1	K	E	T	D	D1
16.00 ±0.1	10.50 ±0.1	10.30 ±0.1	12.00 ±0.1	4.00 ±0.1	5.00 ±0.1	1.75 ±0.1	0.40 ±0.1	1.50 ±0.1	1.50 ±0.1

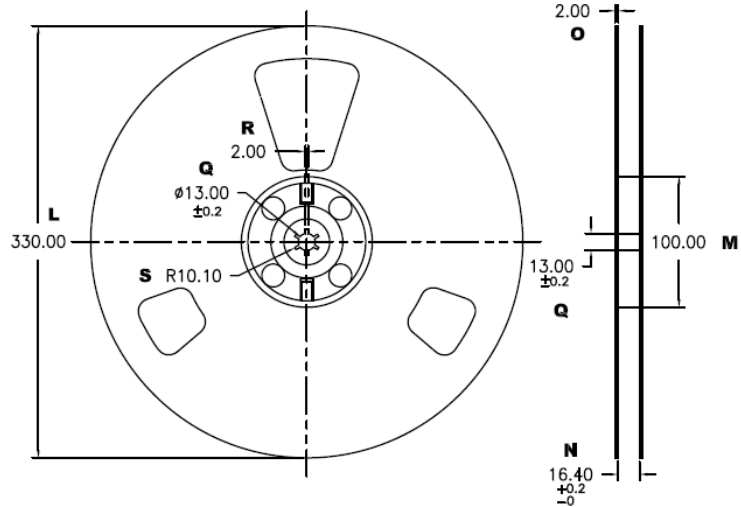

L	M	N	O	Q	R	S
330.00	100.00	16.40 ±0.2	2.00 ±0.1	13.00 ±0.2	2.00	10.00

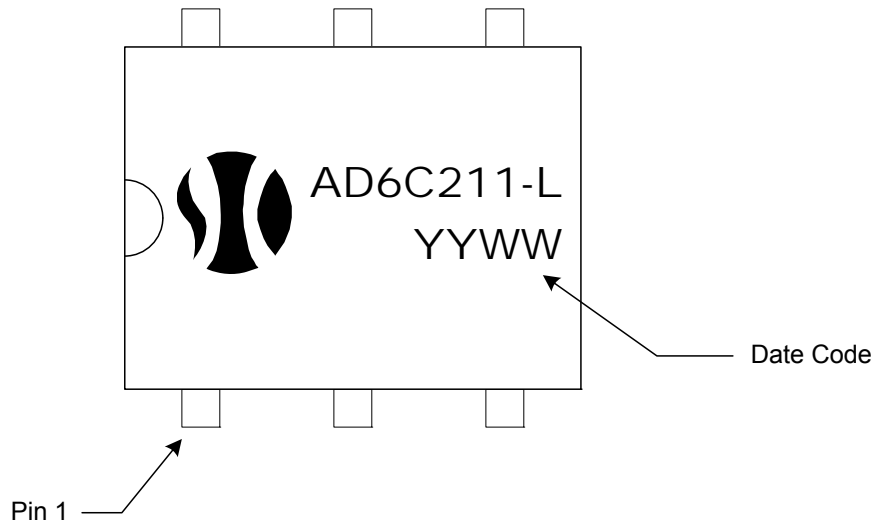
AD6C211-L Package Marking**DISCLAIMER**

Solid State Optronics (SSO) makes no warranties or representations with regards to the completeness and accuracy of this document. SSO reserves the right to make changes to product description, specifications at any time without further notices. SSO shall not assume any liability arising out of the application or use of any product or circuit described herein. Neither circuit patent licenses nor indemnity are expressed or implied. Except as specified in SSO's Standard Terms & Conditions, SSO disclaims liability for consequential or other damage, and we make no other warranty, expressed or implied, including merchantability and fitness for particular use.

LIFE SUPPORT POLICY

SSO does not authorize use of its devices in life support applications wherein failure or malfunction of a device may lead to personal injury or death. Users of SSO devices in life support applications assume all risks of such use and agree to indemnify SSO against any and all damages resulting from such use. Life support devices are defined as devices or systems which, (a) are intended for surgical implant into the body, or (b) support or sustain life, and (c) whose failure to perform when used properly in accordance with instructions for use can be reasonably expected to result in significant injury to the user, or (d) a critical component of a life support device or system whose failure can be reasonably expected to cause failure of the life support device or system, or to affect its safety or effectiveness.