

Application Note 060

SLC800 Linear Optocoupler In An Isolation Amplifier Circuit

Introduction:

Isolation amplifiers are used in a wide variety of applications, including telecommunications, industrial, instrumentation and medical systems. The function of an isolation amplifier is to preserve or amplify a signal across a barrier of galvanic isolation.

The SLC800 is a linear optocoupler designed to provide excellent matching between the output signal and the servo feedback signal to the input. This matching enables the user to achieve excellent signal coupling through an isolation barrier.

This application note is intended to show how the SLC800 optocoupler can be used as the building block for an isolation amplifier circuit.

Description:

The SLC800 consists of an input GaAs LED optically coupled to two photodiodes. One of the photodiodes is typically used in a servo feedback arrangement to the SLC800 input via an operational amplifier. This is referred to as the servo photodiode. The other photodiode is used to feed the output circuitry, typically another op amp. This is referred to as the forward photodiode.

The SLC800 achieves superior linearity using two important functions: 1) the servo feedback setup which linearizes the LED's output; 2) excellent gain matching between the two photodiodes.

LEDs in general exhibit quite non-linear response with respect to time and temperature. The servo feedback is intended to linearize the LED output by taking advantage of op amp functionality to slightly adjust the LED forward current as warranted.

The servo gain, K_1 , is measured as the ratio of the output current of the servo photodiode (I_{P1}) to the input current to the LED (I_F). The forward gain, K_2 , is measured as the ratio of the output current of the forward photodiode (I_{P2}) to the input current of the LED.

$$K_1 = I_{P1}/I_F \quad (1)$$

$$K_2 = I_{P2}/I_F \quad (2)$$

An important parameter is the ratio between the forward gain and the servo gain. This is denoted as K_3 , the transfer gain.

$$K_3 = K_2/K_1 = I_{P2}/I_{P1} \quad (3)$$

For isolation amplifier circuits, it is important that K_3 remain nearly identically constant with varying levels of I_F . The relevant figure of merit is ΔK_3 , the transfer gain linearity. Transfer gain linearity is a measure of the consistency of K_3 , the transfer gain. It is measured as a percentage change in K_3 over varying I_F and temperature conditions. A typical value of ΔK_3 for the SLC800 is 0.1%.

The significance of the consistency of K_3 can best be explained by examining the SLC800 in a typical application circuit. In the next section, we examine the SLC800 in the photoconductive operation. Then, we look at the SLC800 in the photovoltaic operation. In short, K_3 determines how well we can reproduce the input signal at the output.

Photoconductive Operation

The following is a typical application circuit representing the SLC800 used in photoconductive mode:

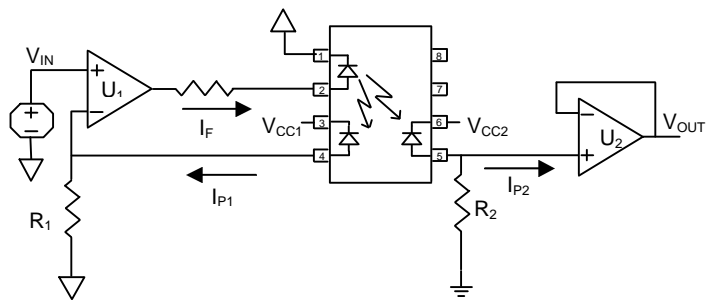

Figure 1: SLC800 in Photoconductive Operation

It is clear from Fig. 1 that this application is restricted to the case of a unipolar photoconductive isolation amplifier. The discussion can be extended to the case of a bipolar photoconductive isolation amplifier;

however, that is beyond the scope of this application note.

We see from Fig. 1 that the photodiode residing at pins 3 and 4 of the SLC800 is used as a servo feedback mechanism to the input via resistor R_1 .

R_1 is chosen such that $V_{in} = I_{P1} \times R_1$ for the maximum expected value of I_{P1} . Of course, this value depends on the maximum operating current of the input LED of the SLC800, $I_{F(MAX)}$.

In other words, we must guarantee that R_1 is chosen such that $I_F \leq I_{F(MAX)}$. Beyond $I_{F(MAX)}$, the SLC800 will either not perform as well or fail to operate altogether. Typical rating for $I_{F(MAX)}$ for the SLC800 is 15 mA.

Example: Suppose $V_{in} = 2$ V, $K1 = 0.004$ and $I_{F(MAX)} = 15$ mA. What value should be chosen for R_1 ?

Solution: Rearranging equation 1 yields

$$\begin{aligned} I_{P1} &= K1 \times I_{F(MAX)} & (4) \\ I_{P1} &= (.004)(15 \text{ mA}) \\ I_{P1} &= 60 \mu\text{A} \end{aligned}$$

$$\begin{aligned} R_1 &= V_{IN}/I_{P1} & (5) \\ R_1 &= 2/(60 \mu\text{A}) \\ R_1 &= 33.3 \text{ k}\Omega \end{aligned}$$

Now, we know from SLC800 operation that $K2$ is closely related to $K1$. In fact, $K3=K2/K1$ is typically very close to 1. Let's assume that $K3=1$; i.e., $K2=K1$.

Thus (rearranging equation 2),

$$\begin{aligned} I_{P2} &= K2 \times I_F & (6) \\ I_{P2} &= K1 \times I_F \\ I_{P2} &= 60 \mu\text{A} \end{aligned}$$

Now we can choose R_2 to give us whatever value of V_{OUT} we desire. If we want $V_{OUT} = V_{IN}$, then set

$$R_2 = V_{IN}/I_{P2} \quad (7)$$

Therefore,

$$\begin{aligned} R_2 &= 2/(60 \mu\text{A}) \\ R_2 &= 33.3 \text{ k}\Omega \end{aligned}$$

More generally,

$$V_{IN} = I_{P1} \times R_1 \quad (8)$$

$$V_{OUT} = I_{P2} \times R_2 \quad (9)$$

$$V_{OUT}/V_{IN} = (I_{P2} \times R_2)/(I_{P1} \times R_1) \quad (10)$$

Using equations 4 and 6, we find:

$$V_{OUT}/V_{IN} = (K2 \times R_2)/(K1 \times R_1) \quad (11)$$

$$V_{OUT}/V_{IN} = (K3 \times R_2)/R_1 \quad (12)$$

This simple design exercise shows that if we know $K3$ we can choose $R1$ and $R2$ to determine the relationship between V_{OUT} and V_{IN} .

Of course, complicating factors exist which will have an effect on the output. As mentioned earlier, $\Delta K3$ due to I_F and temperature is an important parameter. This will determine the precision with which we will be able to replicate the input signal at the output.

Photovoltaic Operation

The following is the typical application circuit representing the SLC800 used in photovoltaic mode:

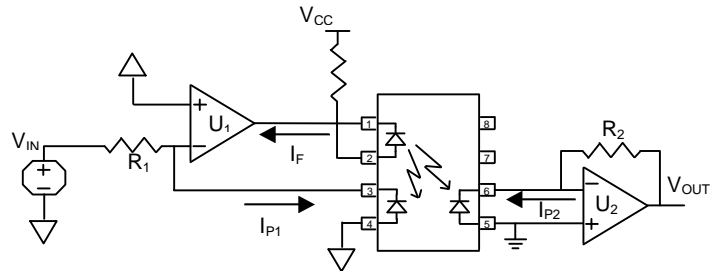

Figure 2: SLC800 in Photovoltaic Operation

It is clear from Fig. 2 that this application is restricted to the case of a unipolar photovoltaic isolation amplifier. The discussion can be extended to the case of a bipolar photovoltaic isolation amplifier; however, that is beyond the scope of this application note.

Also, please note the apparent paradox with respect to the direction of the current through the photodiodes. Although perhaps counterintuitive, positive current indeed flows from cathode to anode due to the direction of the built-in electric field across the depletion region.

To analyze this circuit, we first note that:

$$\begin{aligned} I_{P1} &= V_{IN}/R_1 & (13) \\ I_{P1} &= K1 \times I_F \\ I_{P2} &= K2 \times I_F \end{aligned}$$

Example: Again, if we suppose $V_{in} = 2$ V, $K1 = 0.004$ and $I_{F(MAX)} = 15$ mA. What value should be chosen for $R1$?

Solution:

$$R_1 = V_{IN}/I_{P1} \quad (14)$$

$$R_1 = V_{IN}/(K_1 \times I_{F(MAX)}) \quad (15)$$

$$R_1 = 2/[(0.004)(15 \text{ mA})]$$

$$R_1 = 33.3 \text{ k}\Omega$$

Now if we turn our attention to the output portion of the circuit, we see that:

$$I_{P2} = V_{OUT}/R_2 \quad (16)$$

We are looking for an expression for V_{OUT}/V_{IN} , so we can perform the following manipulation of equations:

$$I_{P2}/I_{P1} = K2/K1 \quad (17)$$

$$(V_{OUT}/R_2)/(V_{IN}/R_1) = K2/K1 \quad (18)$$

$$V_{OUT}/V_{IN} = (K2 \times R_2)/(K1 \times R_1) \quad (19)$$

$$V_{OUT}/V_{IN} = (K3 \times R_2)/R_1 \quad (20)$$

The typical value of $K3$ is 1, however, as long as $K3$ is specified with extreme precision, R_1 and R_2 can be chosen to yield the desired relationship between V_{OUT} and V_{IN} . For example, if $K3 = 0.8$, $R_1 = 100 \text{ k}\Omega$, then we can choose $R_2 = 125 \text{ k}\Omega$ if we want V_{OUT} to match V_{IN} .

Frequency Response (Photoconductive vs. Photovoltaic Operation)

In the photovoltaic configuration, we would expect much lower bandwidth than in the photoconductive setup. However, this is offset by the improved linearity in the photovoltaic configuration.

In the photoconductive configuration, the SLC800 is designed for applications which operate up to 200 kHz. Beyond 200 kHz, the SLC800 was shown to exhibit loss of signal beyond the 3 dB level. In the photovoltaic operation, the SLC800 achieves better linearity and noise performance; however, bandwidth is limited to approximately 50 kHz.

This can be explained as follows: in the photoconductive configuration, we are reverse-biasing the p-n photodiodes, thereby creating a larger depletion region. A photodiode operates much like a parallel-plate capacitor, i.e., the capacitance of a photodiode is inversely related to the size of the depletion region. In the photovoltaic operation, the photodiodes are not biased at all, resulting in a narrower depletion region compared to the photoconductive situation. This results in better bandwidth performance in the photoconductive mode.

The tradeoff is that we achieve better drift performance in the photovoltaic mode. The downside of reverse-biasing the photodiodes is the generation of an undesirable leakage (dark) current. This dark current is significantly affected by changes in temperature. As a result, we lose some of our ability to preserve our input signal to the output in the photoconductive mode.

Conclusion

The SLC800, used in conjunction with complementary amplification circuitry, presents an elegant, low-cost

alternative to traditional isolation amplifiers. The SLC800 takes advantage of SSO's proprietary design to exhibit outstanding transfer gain characteristics. This presents an attractive solution for analog design engineers requiring the functionality of an isolation amplifier.