

## Application Note 015 Introduction to Telecommunications

### Introduction

The purpose of this report is to expose and clarify the basics of telephone line communication. It will analyze the different phases of a typical telephone call and display how solid state technology can be used in these different phases. The report will include how existing products offered by Solid State Optronics, Inc. relate to the telecommunications market. Finally, the report will describe new products being developed by SSO that have been designed specifically for the telecommunications industry.

### How does a telephone line work?

This question can be answered by examining the diagram in Figure 1 and the following explanation:

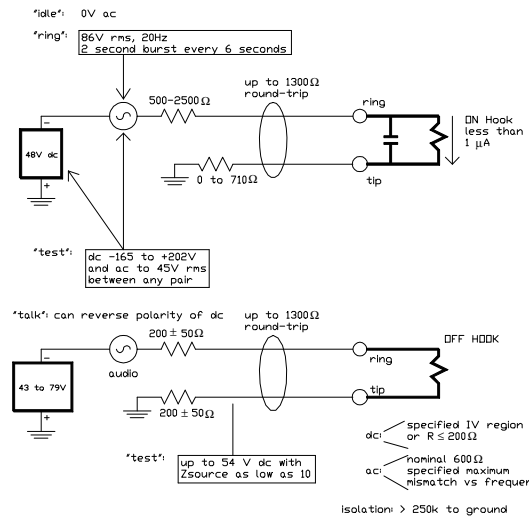

Figure 1: Telephone Line Basics

There are several different states that the phone line can be in, depending upon what the phone is doing, and what the phone company is doing to the phone. The central office (or nearby equivalent) applies various DC and AC voltages to the two-wire phone loop (labeled "tip" and "ring") during these various stages of call progress. In the *idle* state, the telephone company central office applies  $-48(\pm 6)$  V<sub>dc</sub> in series with 500Ω to 2500Ω to the "ring" line, and terminates the "tip" line to ground with 0Ω to 710Ω. In addition, there is typically up to 1300Ω of external line resistance between the central office and the "subscriber". When the phone is placed off-hook, the central office goes into *dialing* mode, applying a dial tone and a DC level of  $-43$  to  $-79$  volts in series with 200Ω ( $\pm 50\Omega$ ) on "ring," and terminating "tip" with the same impedance to ground. The same DC voltage and source impedances are present in the *talking* state (after the connection is made), although the

telephone company may, at its discretion, reverse the polarity of the DC voltage applied to “ring.” Of course, in talking state there are also audio signals superposed on the DC signal, the whole purpose of the telephone! There are two other states. During *ring*, the phone company applies  $89(\pm 2) V_{rms}$  at 20Hz, on top of the usual  $48V_{dc}$  bias. As with the DC signal, the AC ringing signal is applied to the “ring” lead. The official ringing specification is 2 second burst at 6 second intervals. During *test* mode, the phone company applies various AC and DC test signals to make sure that the network is working properly.

Turning towards an application, a typical modem circuit looks like that shown in Figure 2:

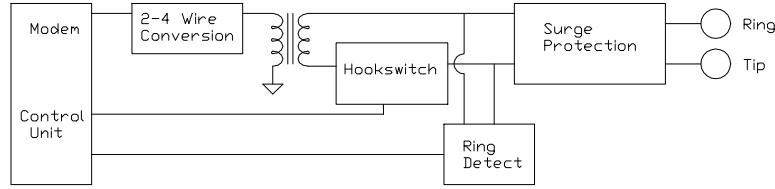

Figure 2: Typical Modem Circuit

The input is a typical common outlet containing leads for the Tip and Ring. The first component to interface with the telephone line is the Surge Protection device. This device is designed to prevent any damage to “downstream” circuitry in the event of any transients which may occur such as lightning or power crossings. The Ring Detect device acts as a sensor and provides a signal to the modem when a “ring” signal is detected from the central office. The Hook Switch component activates the connection of the Tip and Ring lines. Both the Hook Switch and Ring Detect mechanisms are connected to a control unit.

### Surge Protection

This phase of the telephone call is designed to protect the circuitry from any sudden changes in voltage and/or current from the outside line. These changes could result from transients, power crossings, or a lightning strike. According to regulations stated in the FCC’s Part 68 rules, all equipment connecting to the U.S. telephone network must meet certain requirements. Of these, there are two main areas of concern: The Metallic Surge Test and The Longitudinal Surge Test. The Metallic Surge Test is defined as the differential surge voltage across the tip and ring conductors, while the Longitudinal Surge Test is defined as the differential surge voltage across the tip and ring shorted together and ground. The purpose of these tests are to simulate lightning and other transients which may occur on telephone and power lines.

The Metallic Surge Test is the application of an 800V peak surge, with a maximum rise-time-to-crest of 10ms and a 560ms minimum decay-time-to-half-crest applied between tip and ring circuits of the EUT (equipment under test). Two surges are applied, one in each polarity, and the EUT must meet the “non-harm” clause included in FCC Part 68. This clause states that it is acceptable if the EUT remains permanently in the on-hook state (line open), but not acceptable for it to fail and remain in the off-hook state (line closed).

The Longitudinal Voltage Surge Test is the application of a 1500V peak surge in each polarity from the tip connection of the circuit to ground, the ring connection of the circuit to ground and from the tip and ring connections shorted together to ground. The surge must have a maximum rise-time-to-crest of 10ms and a minimum decay-time-to-half-crest of 160ms.

### Ring Detection Circuitry

The ring detection circuitry detects the ring signal from the central office and indicates the presence of an incoming call. This ring signal is a high voltage AC signal superimposed on the central office DC battery, normally 48V DC. The AC signal is transmitted with a frequency between 15.3 – 68.0Hz and has an RMS voltage of 40 to 150 volts, with a typical ring pattern of 2 seconds on and 4 seconds off. The ring detection circuitry is connected to an input port on the modem or micro controller where it is verified as a valid ring signal.

### Hook Switch Circuitry

The on-hook (on-line) and off-hook (off-line) conditions for the phone interface are controlled by the hook switch via a connection with the modem or micro controller host. The hook switch is activated by the modem or host when placing a call or when answering a call in response to an incoming ring signal.

### Solid State Technology and the TR115

With the introduction of solid state technology to the telecommunications market, the different phases of a telephone call can now be handled by solid state relays and optically coupled transistors. Solid State Optronics, Inc. has combined the features of a solid state relay and an optically coupled transistor into a single, 8 pin product called the TR115. Figure 3 shows two TR115 devices connected to the telephone lines in a generic application:

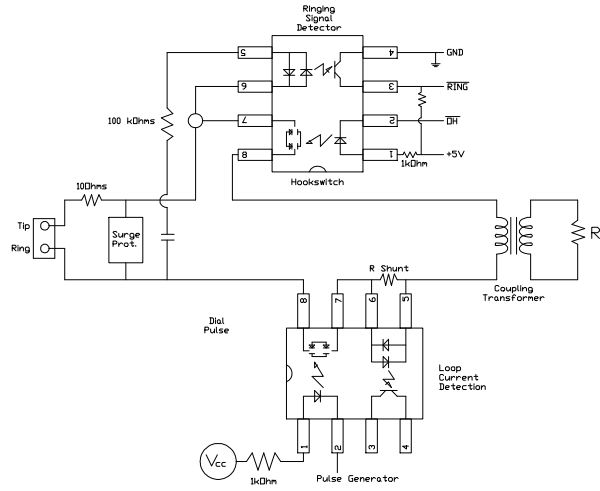

Figure 3: Application Using TR115

In this application, the TR115 devices are used to perform four different functions: Hook Switching, Ring Detection, Loop Current Detection, and Pulse Dialing. For Hook Switch operation the optically coupled relay is used. When a drive current is applied, the relay closes the loop placing the phone or modem in the "Off Hook" mode and prepares it for dialing or receiving an incoming call. Inherent to the optical relay is an isolation voltage of 3750V which provides more than adequate surge protection required by the FCC's Longitudinal Voltage Surge Test. The peak blocking voltage of the relay is 400V<sub>pp</sub>, well above voltages typically encountered along the Tip and Ring lines. The LED driving the relay has typical Turn-On currents around 2mA, making it ideal for battery powered applications such as laptop computers where longer battery life is desired.

For Ring Detection and Loop Current Detection, the transistor portion of the TR115 is used. The low turn on levels and fast switching speeds of the photo transistor make it ideal for these functions. In Ring Detection, the central office signal activates the transistor which denotes an incoming call. In Loop Detection, the transistor is used to monitor whether the device is "On Hook" or "Off Hook."

Modern phones use a method known as DTMF (Dual Tone Multi Frequency) to dial a phone number. Earlier phones used a method known as Pulse Dialing. In pulse dialing, the connection to tip and ring lines is interrupted at a high rate to denote various numbers. For instance, when dialing the number 6, the line would be interrupted 6 times. The relay portion of the TR115 can be used for applications where pulse dialing is used.

## New Developments

As the telecommunications industry grows, new relay technology is being developed for it. With telecommunication products becoming smaller and more powerful, increased multi-functionality must be designed into tinier packages. Solid State Optronics, Inc. has developed several new products to meet these demands, incorporating multiple functions into low profile, 16 pin SOIC packages.

Pictured below in Figure 4 is a schematic of Solid State Optronics, Inc. latest product designed specifically for telecommunication applications, the STS700:

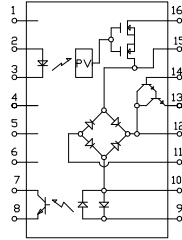

Figure 4: STS700 – Multi Function Relay

Besides containing a 1 Form A relay and a Photo Transistor, the STS700 has a Darlington Transistor and a Bridge Rectifier incorporated into it. These two added features are included in the package for use in “dry” transformer and optical Data Access Arrangement (DAA) designs.

Figure 5 shows how the STS700 is used in a sample circuit:

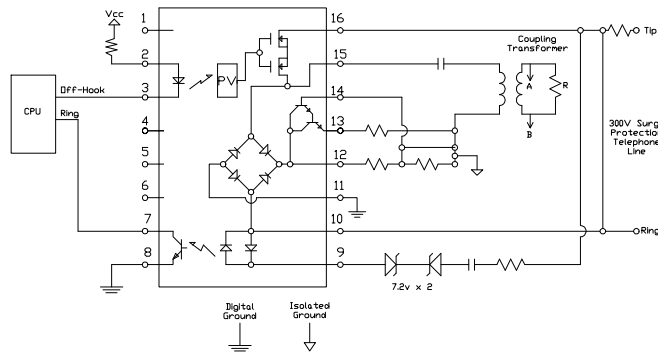

Figure 5: Sample Circuit Using STS700

The Bridge Rectifier provides the function of current steering to maintain DAA operation and protect the Darlington Bridge during polarity reversals of Tip and Ring wires. The Darlington Bridge, with the addition of a few passive components, functions as an electronic inductor that has the effect of presenting a low resistance to the DC current across the telephone line, and a relatively high impedance for AC signals on the line. For a transformer based design, this enables the designer to use a small coupling transformer (T1) since the telephone loop current is diverted through the Darlington instead of the transformer windings (“dry transformer”). Without the electronic inductor, the loop current would have to flow through the transformer (“wet transformer”), however, since the telephone loop current can be as high as 120mA, the transformer would saturate, causing signal degradation unless the geometry of the transformer becomes much larger. This is especially true for high

speed modems such as V.34bis, where return loss must meet or exceed 25dB. Return loss of 25dB is usually not attainable with a wet transformer, and if it is the transformer is too large and expensive for the application.

Solid State Optronics, Inc. is in the process of developing other products based on the 16 pin SOIC package designed for Telecommunications use. These products are all in the STS family, and will be available with the following configurations:

- Two 1 Form A relays, and a phototransistor
- Two 1 Form B relays, and a phototransistor
- 1 Form A relay, 1Form B relay, and a phototransistor
- 1 Form A relay, and two phototransistors

These devices integrate control of Loop Current Detection, Ring Detection, Caller ID, Hook Switching and other functions all into one package, making them ideal for a variety of telecommunications products.

**Conclusion**

The telecommunications industry is a growing market place that has unlimited use for solid state devices. This document has provided an introduction to the basics of the telephone system, and described how products from Solid State Optronics, Inc. can be used to access this system.